



# BMS16T BMS24T

for 2S-16S or 2S-24S LiPo, LiFe & LiTO

Low power consumption

High accuracy

2.8" TFT LCD display

Programmable



**T**hanks for your purchasing the BMS16T or BMS24T for your vehicle.

**R**ead the ENTIRE instruction manual to become familiar with the features/functions of the device before operating. Down load the installation video on [http://www.chargery.com/Video/BMS24T\\_C10325\\_operation\\_instructions.mp4](http://www.chargery.com/Video/BMS24T_C10325_operation_instructions.mp4)

**F**eel free to send an email to [jasonwang3a@163.com](mailto:jasonwang3a@163.com) or call at 86 755 2643 6165 should you have any questions and suggestions.

A handwritten signature in black ink, appearing to read "Jason Wang".

Jason Wang



Chargery BMS16T and BMS24T is designed special for LiPo, LiFe and LiTo battery pack applied to storage energy system and Electrical Vehicle including E-Motorcycle, E-Scooter and so on. The unit can measure or detect the battery voltage, cell voltage, charge & discharge current, battery temperature, and battery SOC (State of Charge), displayed with TFT color LCD.

## Safety Notes

Please read the entire manual completely before using, to make sure you can use this device better and more safely.

1. Ensure the BMS program and settings match your battery pack, otherwise the battery will be damaged and a dangerous situation may arise, especially for Lithium batteries, which may cause fire.
2. For storage energy system application and for Electrical vehicle application will have many differences, please adjust those key parameters carefully, or contact us for more details.
3. Do not allow water, moisture, metal wires or other conductive material into the device.
4. Never charge or discharge any battery having evidence of leaking, expansion/swelling, damaged outer cover or case, color-change or distortion.
5. Do not try to charge "non-rechargeable" dry cells.
6. Do not mix batteries of different types, different capacities or from different manufacturers.
7. Do not exceed the battery manufacturer's suggested maximum charge and discharge rates.
8. Carefully follow the battery pack manufacturer's recommendations and safety advice.



## Warning

1. External power supply and battery charger don't have a common ground
2. Current shunt don't contact to any metal including BMS metal case
3. BMS case don't contact to any metal
4. Current shunt must connected to Battery pack negative
5. Prevent BMS from vibrating violently to make sure BMS case don't contact to battery pack negative
6. If power BMS by battery pack, the total current driven charge and discharge relay must be less than 1A, the charge controller and discharge controller voltage is battery pack voltage, so the relay coil voltage must be accordance with battery voltage.

## Copyright

**Copyright@Chargery Power Co., Ltd. All rights reserved.**

Without prior written consent by Shenzhen Chargery Power Co., Ltd, any units or individual extract and copy parts or entire contents of this manual, and transmission in any form is illegal and strictly prohibited.

The product described in this manual, may include copyright software ownership belonged to Shenzhen Chargery Power Co., Ltd and its licensee, except getting the permission from relevant rights holders, otherwise any copy, distribute, modify, excerpt, decompile, disassemble, decrypt, reverse engineering, lease, transfer, sub-license, as well as other acts of infringement of software copyright is strictly prohibited, but apart from the restrictions prohibited by applicable law.



## Special Features

1. The BMS24T uses advanced ADC measurement technology, high accuracy, high voltage and high current detection circuit. The maximum voltage measurements tolerance is within 5mV at up to 24S LiPo battery (102V)
2. Support regenerative braking, during braking operation can charge the batter pack and the discharge power (Wh) will decrease to response to the braking power.
3. Charge/discharge current up to **600A**. Bigger current can be customized.
4. **1.2A** per cell balance current is very useful for large capacity battery pack, the feature can resume all cell voltage balance status at the shortest time. Over temperature protection make sure the system safety during balance.
5. BMS24T calculate and display the charge and discharge power (Wh), generally the battery rated power is rated voltage multiply rated battery capacity.
6. TFT LCD screen provides rich information including current, voltage, power, capacity, battery status, SOC and temperature and so on.
7. BMS24T features a maximal safety protection, within the range parameters can be setup, BMS24T will alarm and cutoff charge or discharge according to users' setup, out of range of parameters, and trigged absolute maximum ratings BMS24T will force to cutoff charge or discharge to prevent the battery from fire.
8. Minimize the power consumption by draw current from all cells or external power supply.
9. Dual power design, the unit can be powered by all cells or external power supply.
10. Detect cell count at any time, and compare with the count detected when switch on first time. If it is not uniformity, the device will alarm and cutoff charge or discharge according to users' setup, the feature can prevent any cell connection from loosing.
11. Sound alarm and LED alarm will be triggered when any warning events happened, and then wait several seconds cut off or Don't cut off charge or discharge. The delay time can be programmed.
12. Charge relay and discharge relay are controlled independently.
13. Two temperature sensors monitor battery temperature on different position.
14. Supports upgrading the firmware program by USB port.
15. BMS24T provide users the maximal flexibility, key parameters can be programmed.
16. BMS24T display battery SOC or called battery gauge similar with car dashboard. Cell count, battery pack voltage and battery gauge (%) is displayed simultaneously.
17. In case that the battery pack need not be charged and discharged, Press **STOP** button enter into sleep mode to save energy consumption, at this mode, Charge and Discharge is forbidden, and LCD back light is off. Press any key to resume normal work mode.
18. LCD back light ON time can be programmed to save energy, when it is OFF, press any key to resume "ON".

## Protection functions

1. Cell count error protection
2. Over charge protection
3. Under voltage protection
4. Over current protection when charge or discharge
5. Over temperature protection
6. Over differential cell voltage protection
7. Over differential battery temperature protection
8. Under SOC protection

## Interface

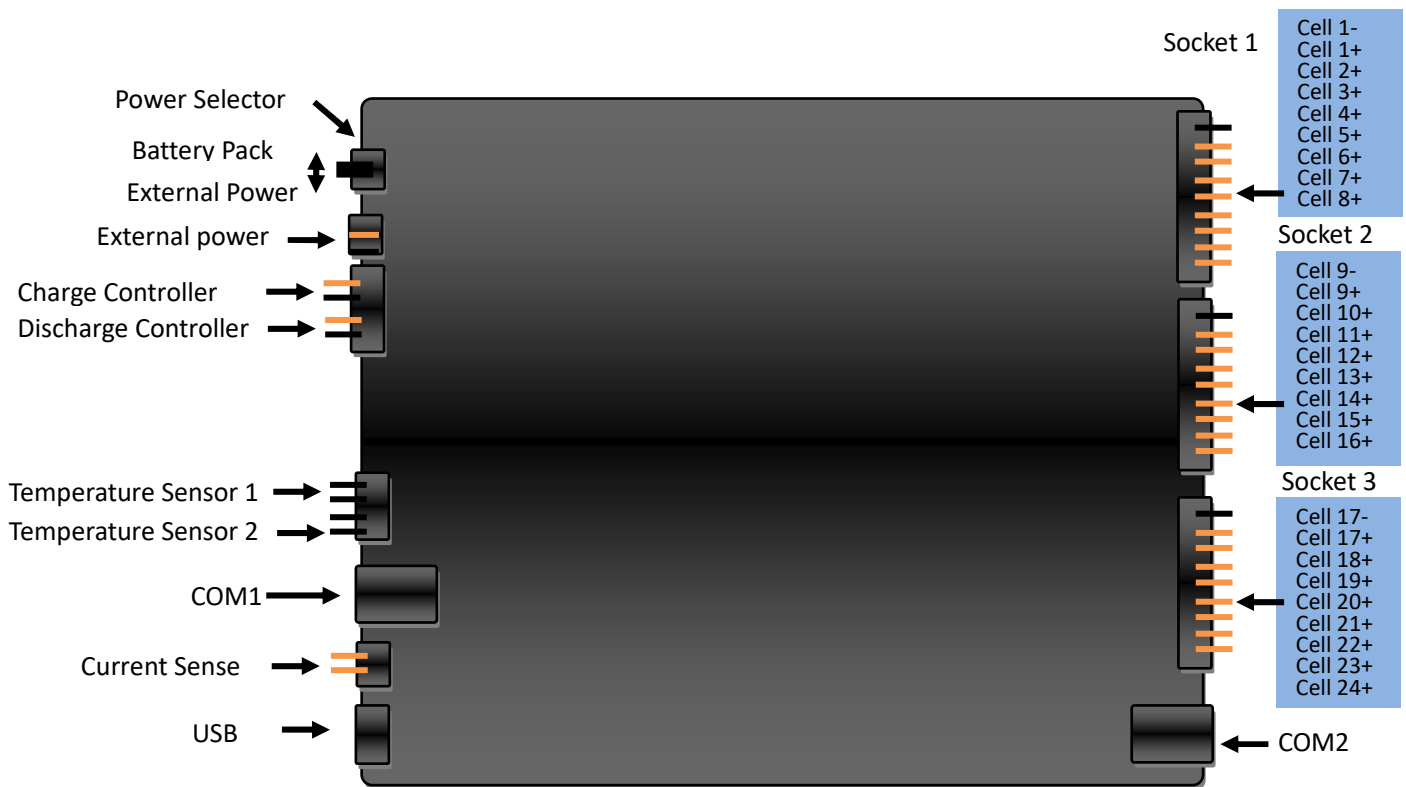

BMS24 main module



BMS24 display module



Power Selector	Alternate External power supply or battery pack to power BMS24T. If select battery, the battery pack must be 8S to 24S LiFe or LiPo or LiTO. But if power by external power supply, BMS24T can do 2S-24S LiPo or LiFe battery pack. The main input supply <b>Vin</b> voltage range is 15V to 60V
External power port	External power input, the voltage should be 15V to 60V, 1A minimum, the current depends on the relay coil, the connector is 5.5*2.1 DC jack,
Charge controller	Charge controller, turn on or turn off charge circuit, generally connect to relay or DC contactor. When any cell voltage is over setup, it will make relay "OPEN" to turn off the charger, otherwise BMS24T will output <b>Vin</b> power the coil to close the relay. The relay must be form OPEN.
Discharge controller	Discharge controller, turn on or turn off discharge circuit, generally connect to relay or DC contactor. When any cell voltage is under setup, it will make the relay "OPEN" to turn off the motor or other load, otherwise BMS24T will output <b>Vin</b> power the coil to close the relay. The relay must be form OPEN.
COM1	The COM1 port (black connector) is connected to external device such as Charger. If connect to Chargery charger, BMS24T can control charge current to shorten charge time
COM2	The COM2 (gray connector) port is connected to main unit and display module by gray spring wire
Temperature sensor	Two temperature sensors monitor the battery temperature, the sensor must tie to battery surface or gap of cells where the temperature should be the highest during charge or discharge. The temperature range is -20 to 150°C
LED <sup>1)</sup>	Connect to high light LED, the LED will flash when any warning event happened
Beeper <sup>1)</sup>	Connect to beeper or others to alarm. It will output 12V 25mA max.
Current sense	Connect to single current shunt. Charge current and discharge current can be measured simultaneously.
USB	Connect to PC update the firmware by Chargery UpdateTool.exe
Socket 1	Connect to 2S to 8S battery,
Socket 2	Connect to 9S to 16S battery. for over 8S battery, please connect 8S battery to socket 1 and then connect to socket 2, such as 8S + 2S for 10S and 8S +5S for 13S
Socket 3	Connect to 17S to 24S battery. for over 16S battery, please connect 8S battery to socket 1 and second 8S to socket 2, then connect other cells to socket 3, such as 8S + 8S + 6S for 22S

Note:

- 1) On the BMS display module

## Absolute maximum or Minimum ratings

Maximal cell voltage	LiPo	4.35V	Larger than the absolute maximum voltage, BMS24T will force to cut off charge
	LiFe	3.90V	
	LiTO	2.80V	
Minimum cell voltage	LiPo	2.50V	Less than the absolute minimum voltage, BMS24T will force to cut off discharge
	LiFe	2.00V	
	LiTO	1.50V	
Battery temperature	LiPo&LiFe&LiTO	80°C	Over the temperature, BMS24T will force to cutoff the charge and discharge

## Program Setup

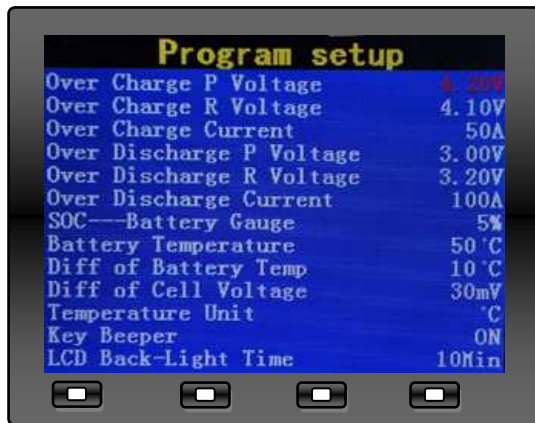

1. Press **SET/START** button for 3 seconds enter into Program Setup interface.
2. Press **UP** or **DOWN** button select the item, press **SET/START** shortly make the value flash, and press **UP** or **DOWN** change the value. Press **SET/START** button shortly confirm the change. After finish all setup, press **SET/START** for 3 seconds quit the setup menu.
3. When quit setup mode, BMS24T will record all parameters till next change.



**NOTE: Please keep the default setup unless for special purpose.**

Parameters		Min.	Type	Max.	Step	unit
<b>Charge Protection</b>						
Over Charge Protection(P) Voltage	LiPo	3.90	4.20	4.35	0.01	V
	LiFe	3.40	3.65	3.90	0.01	V
	LiTO	2.50	2.75	2.80	0.01	V
Over Charge Release(R) Voltage	LiPo	3.80	4.10	4.25	0.01	V
	LiFe	3.30	3.55	3.80	0.01	V
	LiTO	2.40	2.65	2.70	0.01	V
Over Charge current		0	<b>50</b>	600	1	A
<b>Discharge Protection</b>						
Over Discharge Protection(P) Voltage	LiPo	2.75	3.00	4.00	0.01	V
	LiFe	2.00	3.00	3.50	0.01	V
	LiTO	1.50	1.85	2.40	0.01	V
Over discharge Release(R) Voltage	LiPo	2.75	3.20	4.00	0.01	V
	LiFe	2.00	3.10	3.50	0.01	V
	LiTO	1.60	1.95	2.50	0.01	V
Over Discharge current		0	<b>300</b>	600	1	A
SOC--- Battery gauge		5	20	90	1	%
<b>Temperature Protection</b>						
Battery Temperature		30	50	80	1	°C
Difference(Diff) of battery Temperature(Temp)		5	10	30	1	°C
<b>Voltage balance Protection</b>						
Difference(Diff) of cell voltage		5	30	300	1	mV
<b>Others</b>						
Temperature Unit			°C	°F		
Key Beeper			ON	OFF		
LCD Back-Light time <sup>(1)</sup>		1	10	999	1	min
Cut-Off Delay Time <sup>(2)</sup>		0	10	60	1	Second
Current Calibration <sup>(3)</sup>		0	0	255	5	A
Temperature Alarm <sup>(4)</sup>		ON		OFF		
Cell Empty Voltage <sup>(5)</sup>		1.50	2.50	4.34	0.01	V
Cell Full Voltage <sup>(5)</sup>		1.51	4.20	4.35	0.01	V
Default settings	Press <b>SET/START</b> restore all parameters to default value before delivery					
<b>Balance Parameter setup: Press SET/START to setup and press for 3 seconds quit setup</b>						
Balance Start Voltage <sup>(6)</sup>	LiPo	3.3	3.6	4.1	0.01	V
	LiFe	3.0	3.2	3.4	0.01	V
	LiTO	1.75	2.20	2.6	0.01	V
Balance Stop Diff Voltage <sup>(7)</sup>			5	12	200	mV
Balance in Charge	ON means Balance start during charge, OFF disable.					
Balance in Discharge	ON means Balance start during discharge, OFF disable.					
Balance <sup>(8)</sup> in Storage	ON means Balance start during storage, OFF disable.					



**NOTES:**

1. **Always on** means the LCD back-light will be ON forever.
2. **NO** means BMS24T will not cut off charge or discharge but alarm by LED flash and Beeper Sound.

**Cut-Off Delay Time** is very important and difference for different battery capacity and application, please carefully test and make a correct decision, for EV, you can select **NO** to control the EV car by manual **NOT** controlled by BMS24T, but when cell voltage and temperature trigger the absolute maximum or minimum ratings, the BMS24T will force to cut off charge or discharge to make sure the battery safety, and prevent battery pack from explode or fire.

3. **Current Calibration** is not recommended unless use new current shunt. Voltage and current is calibrated before delivery.
4. Temperature Alarm OFF means battery temperature and Difference of battery Temperature is unable.
5. Cell Empty Voltage and Cell Full Voltage is to set up cell voltage bar graph, the value should be as same as Over Charge Protection(P) Voltage and Over Discharge Protection(P) Voltage
6. Setup the battery starting voltage, when minimum cell voltage over the setup, balance will start automatically
7. Setup the minimum cell difference, when difference of cell voltage under setup, stop balance automatically
8. Balance switcher, default Balance is OFF,
  - a) If balance in storage setup ON, balance will start in storage status, STORAGE means charge or discharge current under 1A. So the current shunt and current sensor wire must be connected to BMS. **When driving the car, balance in storage OFF is suggested. For storage system, ON is better.**
  - b) If balance in charge setup ON, balance will start in charge
  - c) If balance in discharge setup ON, balance will start in discharge
  - d) Balance current is 1.2A max. per cell,



## Balancer

BMS24T can resume cell voltage balanced status at the shortest time, it is based on 1.2A balance current per cell, balancing accuracy is 8mV. Balance can be operated in charge or in discharge or in both, the feature can be setup on program setup menu. The balance function is unable before delivery, after the BMS display each cell voltage, please enter into program setup menu to enable balance.

Although balance current per cell is larger than other brand BMS, Chargery BMS24 use temperature protection prevent BMS from overheating.



## Operating guideline

1. Connect Beeper, LED, and Current Sensor to BMS24T main module, and then connect relay Controller and temperature sensor too.
2. Connect main module to display module by COM2 port
3. Connect the battery to BMS24T, keep the cell polarity correct. The detailed connection diagram is as the following typical connection drawings.
4. Move the power selector turn on the device.
5. BMS24T will initialize the beeper and LED, beeper sounds once time, then display BMS24T and version, the battery type and cell count interface is displayed. Three battery type LiPo, LiFe and LTO can be selected. Cell count range is 2S to 24S, the cell count will be identified when the battery pack connect to the BMS24T. Press **DOWN** or **UP** button choose the item and press **SET/START** blink, then press **DOWN** or **UP** button modify, finally press **SET/START** button to run the BMS24T. After started, battery type and cell count will not be changed unless power off BMS24T. Each cell voltage and other data are displayed correctly. If cell voltage is not displayed correctly, please check the battery connection.
6. Press **SET/START** button for 3 seconds enter into Program Setup interface, modify Over Charge Current (50A default) and Over Discharge Current (300A default) according to your application. If need balance in Charge or in Discharge, please modify the Balance set on Program Menu. the balance function is off before delivery
7. SOC—battery gauge dashboard will be displayed first, as following. Press **UP/DOWN** button alter other interface.

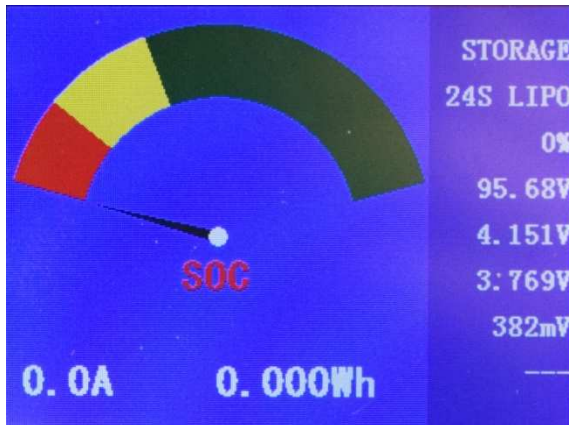
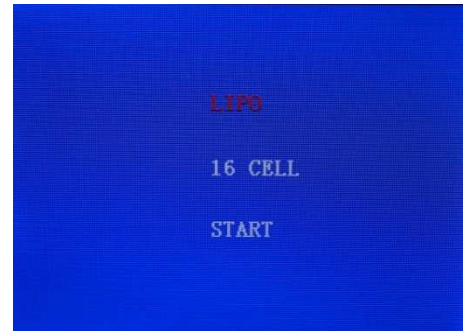

Charge or discharge  
current

Charge or discharge  
power

STORAGE is battery status, maybe CHARGE or DISCHARGE <sup>(1)</sup>  
 Cell count and battery type  
 SOC—battery gauge, display 0% lose temperature sensor  
 Battery pack voltage  
 Highest cell voltage  
 Lowest cell voltage  
 Difference of cell voltage  
 Battery temperature

### Notes

When charge or discharge current less than 1.0A, battery status will be STORAGE.

8. The following interface is cell voltage bar graph, the highest and the lowest cell voltage is displayed in RED



column.

9. The third interface display all information including all cell voltage. The highest and the lowest cell voltage is displayed in RED text. Difference of cell voltage and difference of battery temperature is displayed.

When any warning events triggered, BMS24T will go to the interface and display error information. Such as if the battery connection break down, the cell count and ERROR will be displayed in turn. If the cell voltage over the setup value, the cell voltage and HIGH will be displayed in turn.

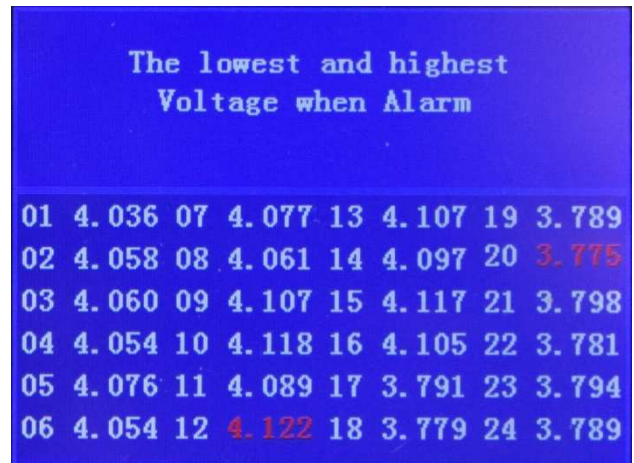

10. When any warning events triggered, Press UP or DOWN, you can check the cell voltage triggered warning events (over charger or over discharge), the voltage will be recorded till next warning.

## Specifications

1. Battery range: 2S-24S LiPo & LiFe, LTO battery pack on BMS24T, 2S-16S LiPo & LiFe, LTO battery pack on BMS16T
2. Accurate scope of the cell voltage: -8mV/+8mV on BMS24T, -5mV/+5mV on BMS16T
3. Cell Voltage display range: 0.10~4.99V
4. The voltage of external power: 15-60V
5. Balance current: 1.2A per cell
6. Temperature display range: -20°C~150°C,
7. SOC indicator:
  - RED area @ 0~15% of SOC
  - YELLOW area @ 16~35% of SOC
  - GREEN area @ 36~100% of SOC
8. Main module Size: 128×114×33 (L×W×T, mm) or 5.1×4.5×1.3 (L×W×T, inch)
9. Main module weight: 420g excluding accessories
10. Display module size: 96×80×24 (L×W×T, mm) or 3.8×3.2×0.95 (L×W×T, inch)
11. Main module weight: 130g excluding accessories
12. Warning LED: 11000mCd, @ 2.0V, 20mA
13. Warning beeper: 85dB @ 12V, 25mA
14. Package: AL alloy case



## Current shunt and Current Sensor Specifications

Please use correct current shunt according to actual maximal charge and discharge current, single shunt is enough for BMS24T, 75mV or less shunt is suggested.

Chargery can provide all kinds of shunt. All cell voltage and current are calibrated before delivery.

The 300A and 600A 75mV specification is as below.

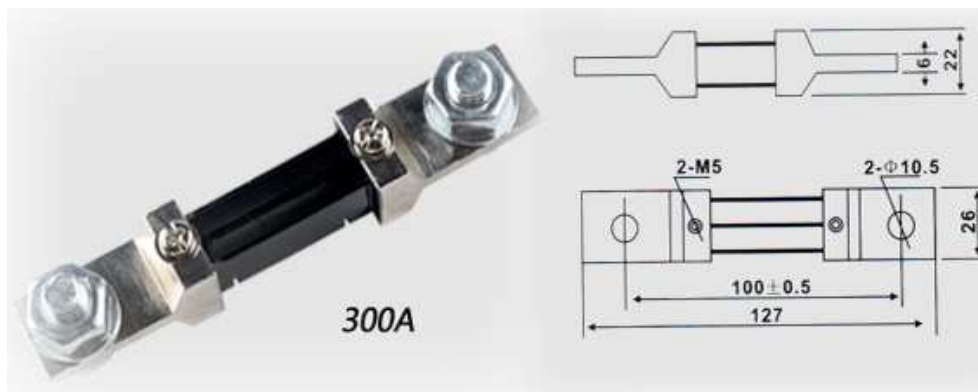

300A shunt weight: 230g

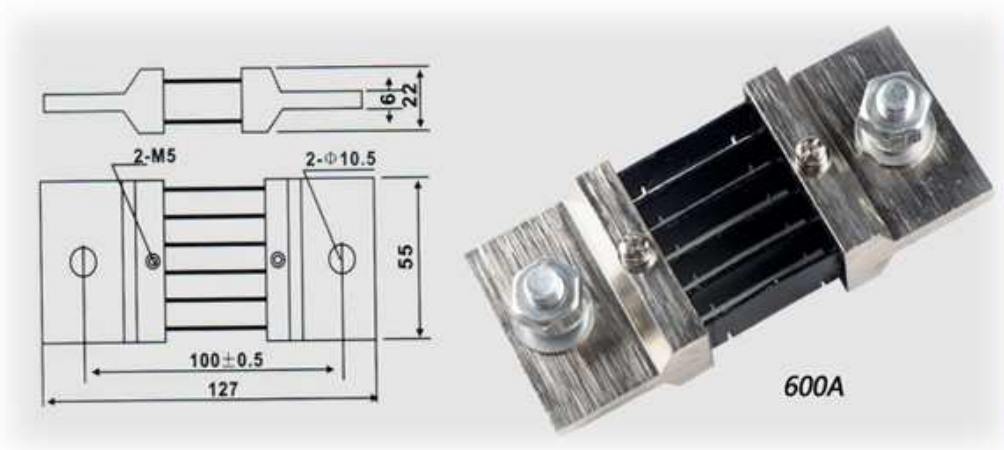

600A shunt weight: 530g

## Current sensor wire



## Current Calibration

Press **SET/START** 3 seconds enter into Program Setup and find the Current Calibration, you can calibrate the current to improve the measure accuracy. If use new current shunt, the current must be calibrated again.

1. Turn off charge and discharge, make the current blink, press **UP/DOWN** modify the value to zero, shortly press **SET/START** button finish 0A calibration.
2. Connect the current shunt as following calibrate charge current

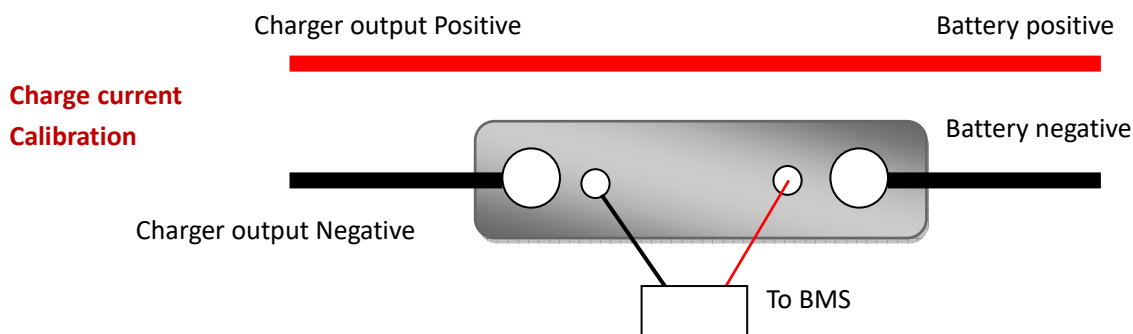

3. Shortly press **SET/START** make the current blink and increase the current to new value (up to 125A, it must be less than current shunt, it is better to make it equal to your charge current, the key is the current must be accurate), turn on charger and charge battery at the current, 3 seconds later, press **SET/START** save the charge current calibration.
4. Connect the current shunt as following calibrate discharge current

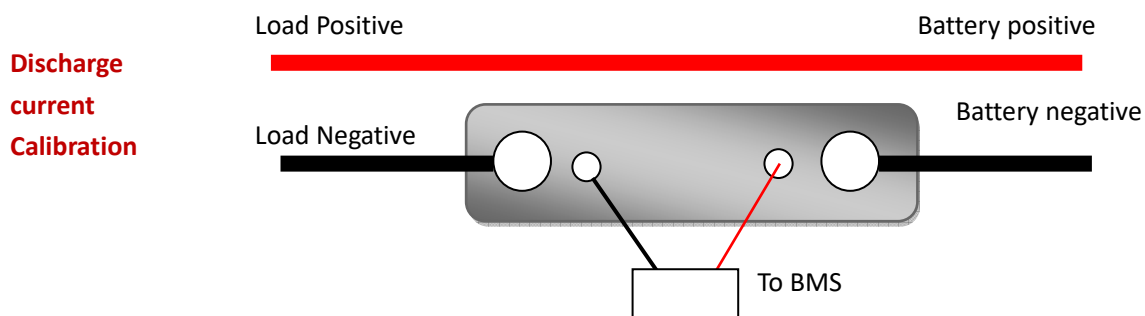

5. Press **SET/START** again and decrease the calibration current to new value (up to -125A, it must be less than current shunt, it is better to make it equal to your motor current, the key is the current must be accurate) turn on motor and discharge battery at the current, 3 seconds later, press **SET/START/** save the discharge calibration.
6. Turn off motor, Press **SET/START** for 3 seconds quit Program Setup, current calibration is finished.



## Firmware Upgrades via USB Port

1. Go to <http://www.chargery.com/uploadFiles/ChargeryupdateTool.zip> to download the ChargeryupdateTool.zip, the zip file include Chargery USB driver, and Chargery Update Tool, extract to any disk on the PC.
2. To install the USB driver, run the program X:\ChargeryupdateTool\ChargeryUSBdriver.exe (where X is the drive letter designator), don't install driver automatically on win10
3. In the same directory, double click to run the update tool and enter program interface.
4. Connect BMS24T to the PC by the USB data cable. When the port number (such as com5) appears, this shows the update tool identified the BMS24T. Click OPEN button lock the port please.
5. Click Open File button load the firmware file. If there is no firmware file on the PC, you can download the file on <http://www.chargery.com/uploadFiles/firmwareFiles/> to the PC.
6. Click the Update button, then the update progress bar will appear, update complete will be displayed on PC. BMS24T also display the progress bar simultaneously and enter into cell count setup interface automatically after update is completed..

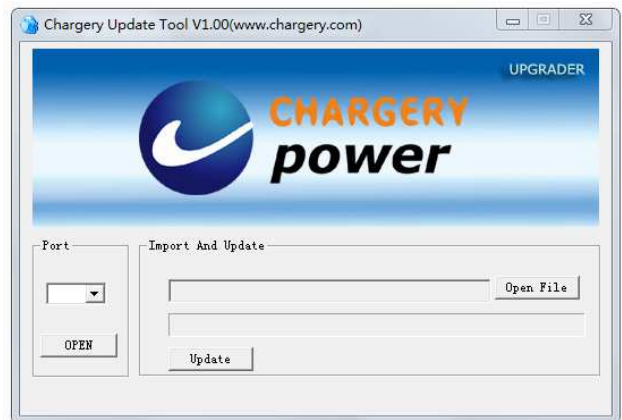

## Typical Connection

There are 3 sockets connecting to battery pack, socket 1 is for 2S-8S, socket 2 for 9S~16S, and socket 3 for 17-24S battery.

1. 6S battery connect to the socket 1 directly, but external power supply is essential, it is as following.

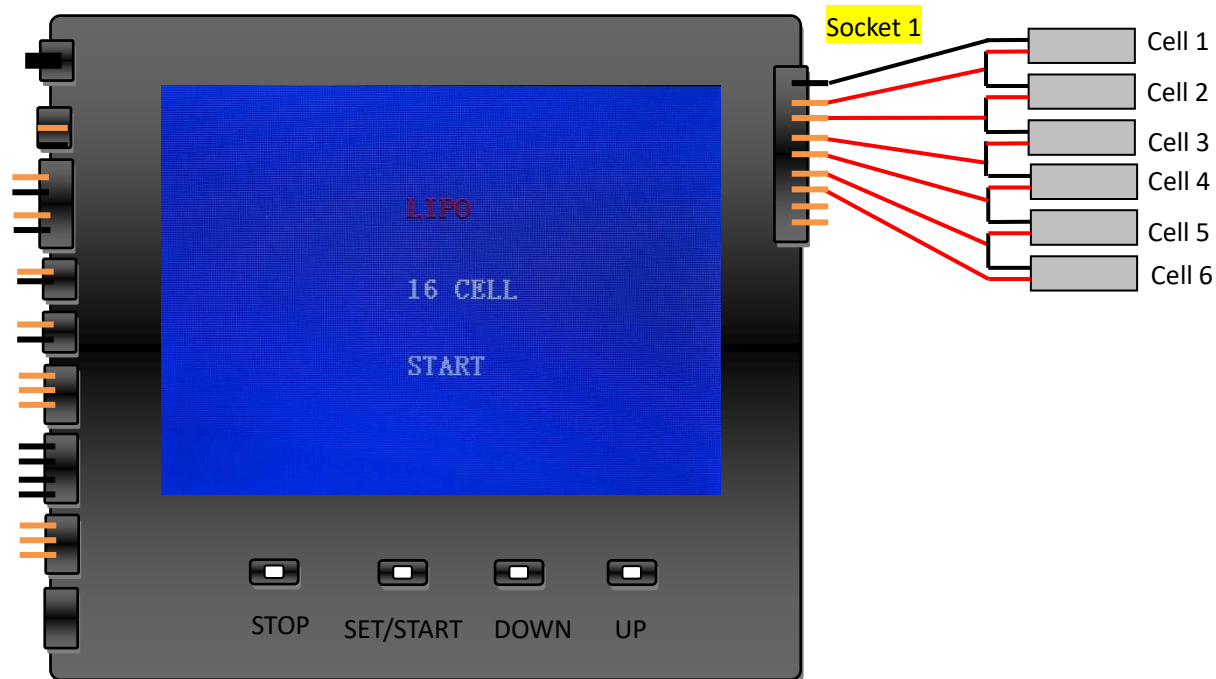

2. For over 8S battery pack, connect 8S to socket 1 and then socket 2 separately. Take 12S battery sample as following:

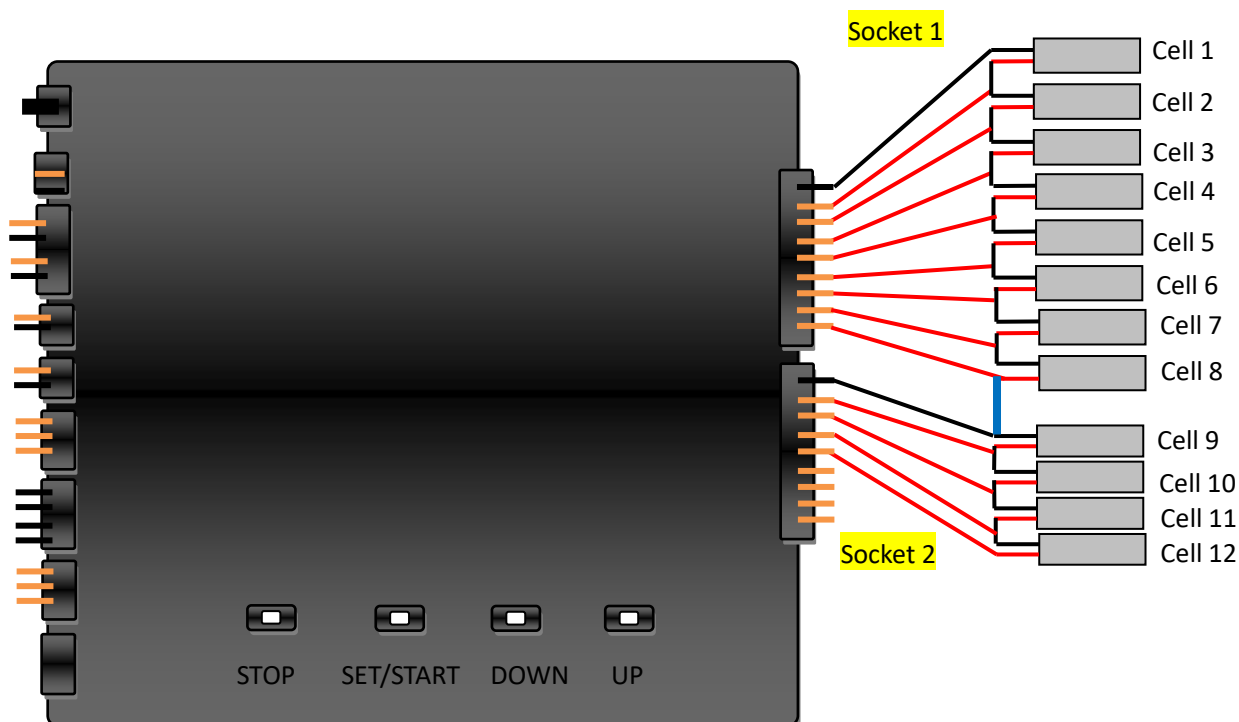





24 cells connected in series

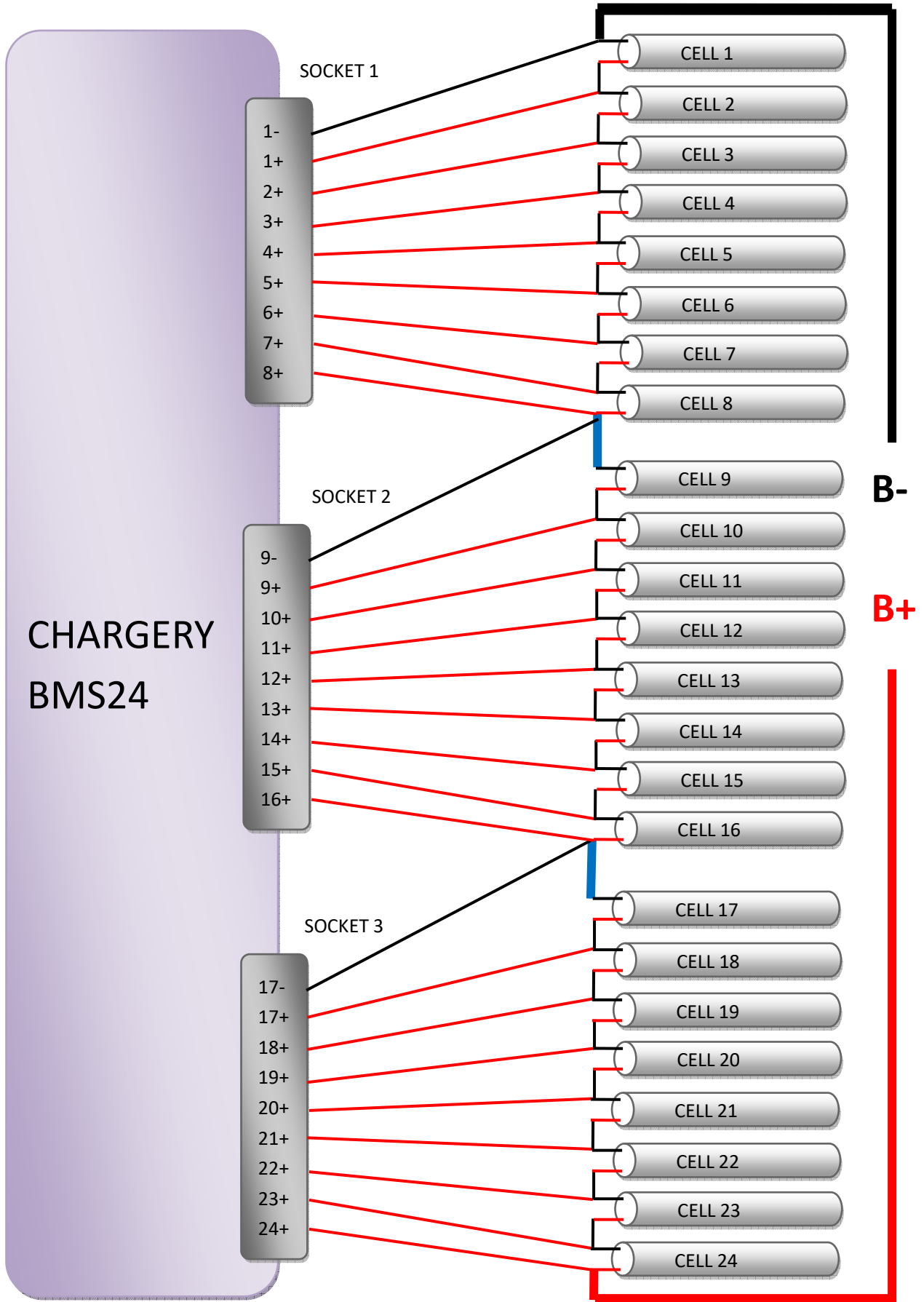

4S+4S+6S=14S, 14S cells connected in series

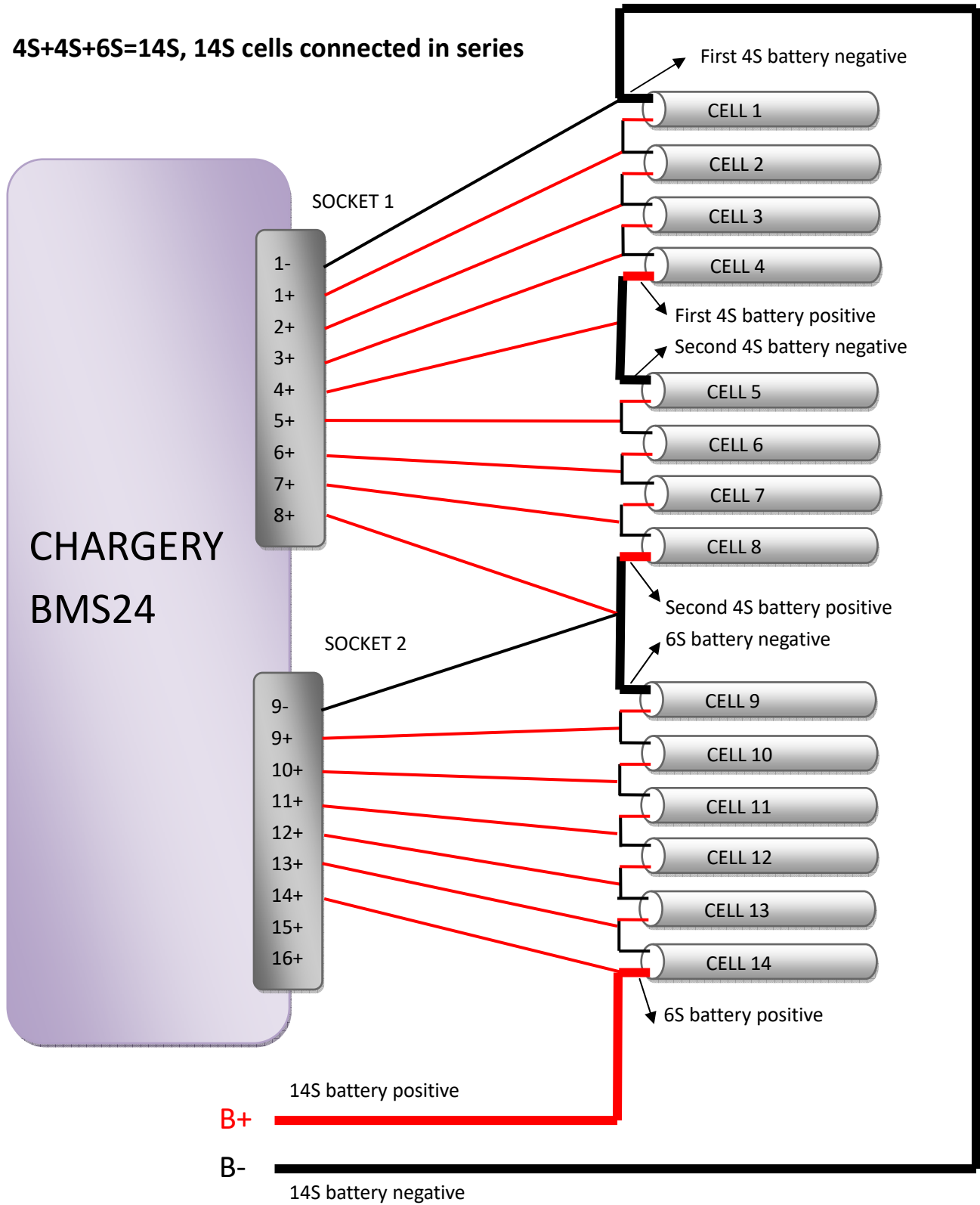

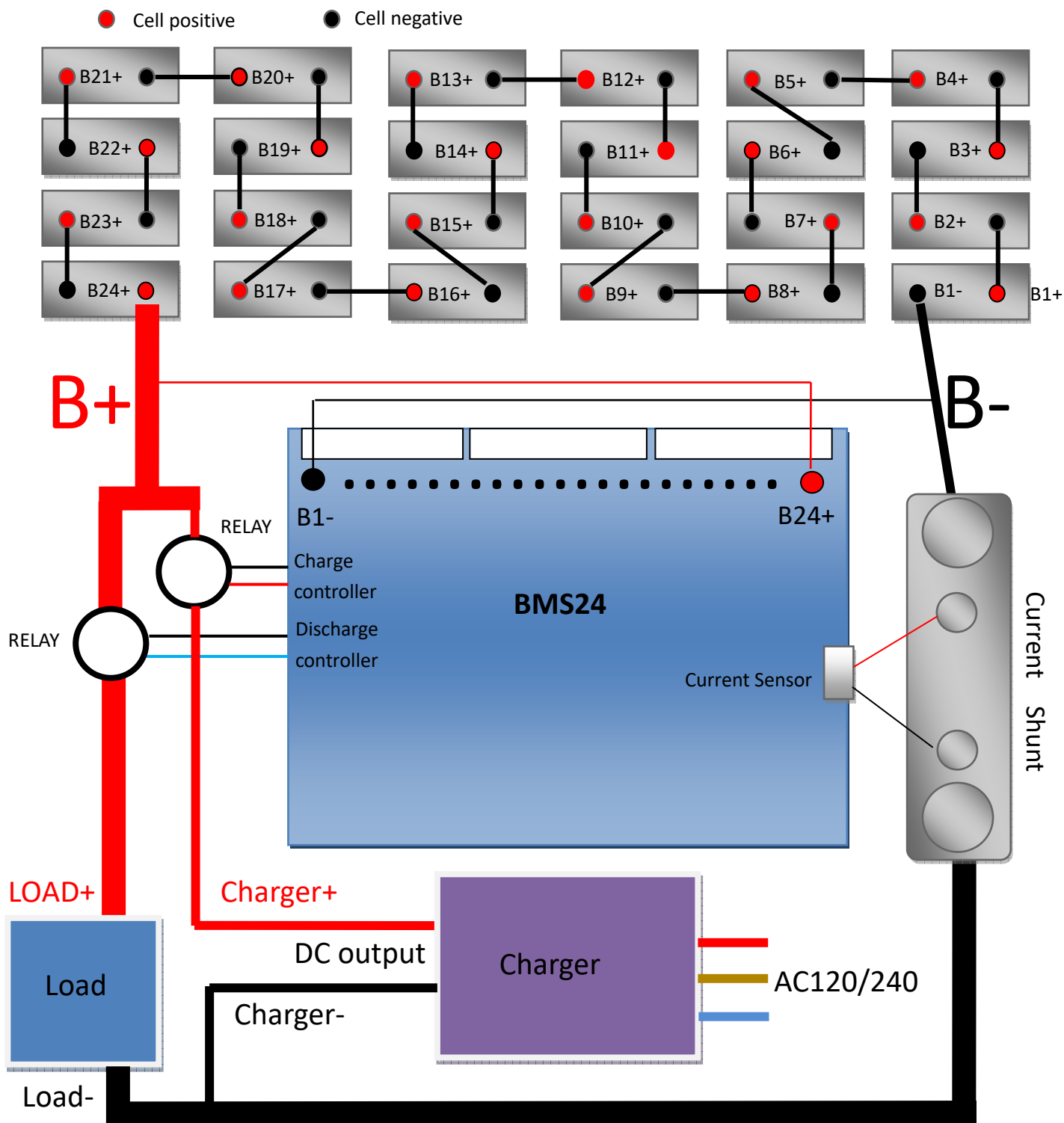

Heavy RED wires are positive of battery pack (B+/B24+), charger and load such as motor, and heavy black wire is negative of battery pack(B-/B1-), charger and load.

### Warning

Before connect the relay to charge or discharge controller, please confirm the coil of relay voltage. The BMS controller will output  $V_{in}$  to power the coil, if the BMS24 will be powered by external power supply,  $V_{in}$  is external power supply output voltage, if powered by battery pack,  $V_{in}$  will be battery pack voltage. If the  $V_{in}$  is not correct on driving coil, please use voltage regulator to power coil.

## Charge relay and discharge relay lectotype for BMS24T

If BMS24 is powered by battery pack, the following items should be considered on using relay.

1. Battery pack voltage range should be accordance with relay coil drive voltage scope. When battery pack is fully charged, the pack voltage is the highest and when the battery is discharge to flat, the pack voltage is the lowest. The relay controller voltage on BMS is battery pack voltage for 8S-16S, and the controller voltage is 16S battery pack voltage for 17S-24S.

If controller voltage is not suitable, a buck or boost regulator is essential, the simplest method is use a resistance to decrease the controller voltage to fit with coil voltage.

The relay controller can provide 1A current max.



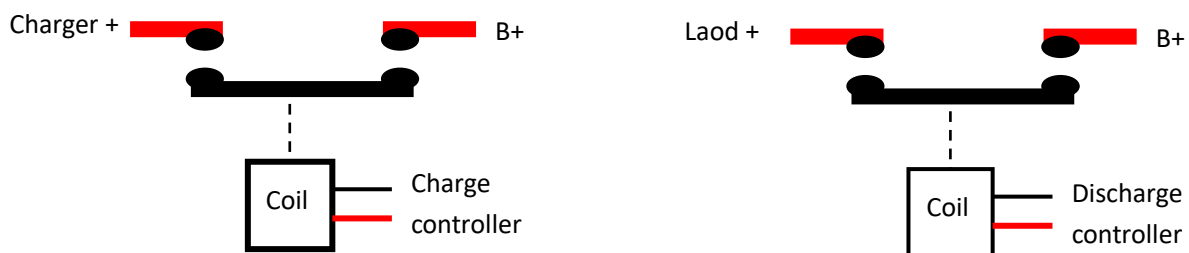



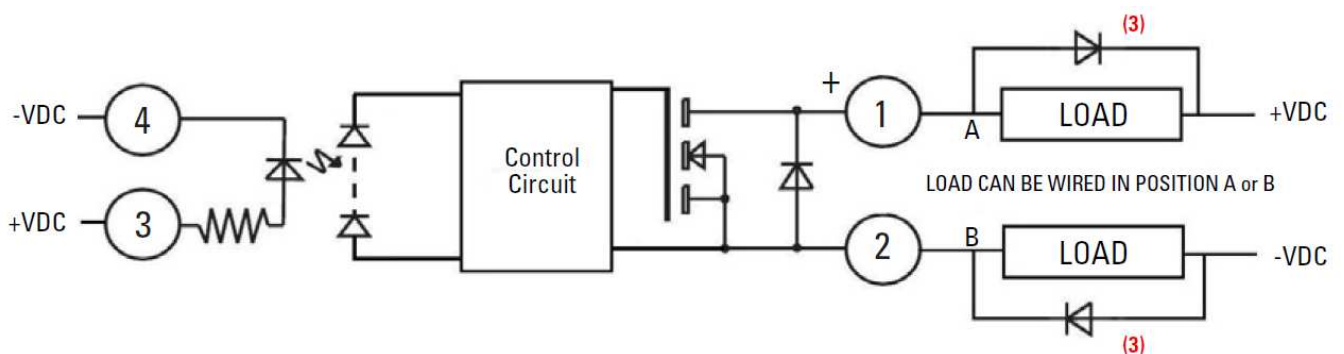

2. Relay DC current should be over 1.2 times as charge or discharge current. If discharge current is 100A, 120A relay for discharge is suitable.
3. If BMS24 is powered by external power supply, the external voltage should be accordance with relay coil drive voltage.



4. For solid state relay, the driven voltage (+VDC, -VDC), adequate Heats Sink and rated load current is very important, please pay attention to its wire connection.



## Accessory

<p style="text-align: center;"><b>USB data cable</b></p> 	<p style="text-align: center;"><b>Battery connection XHR-9PIN, 600mm</b></p> 
<p style="text-align: center;"><b>Temperature sensor, 600mm</b></p> 	<p style="text-align: center;"><b>Relay controller wire 600mm</b></p> 
<p style="text-align: center;"><b>Warning LED, 300mm</b></p> 	<p style="text-align: center;"><b>Warning Beeper, 300mm</b></p> 
<p style="text-align: center;"><b>Current sensor wire, 600mm</b></p>	<p style="text-align: center;"><b>Communication wire (3 meters)</b></p>
	







## Total solution on E-Vehicle application

If use Chargery charger, the charge relay can be ignored, BMS24T can communicate with charger, when any cell over charged, BMS will send signal to charger, the charger will decrease charge current till the cell voltage under safe value. If use other brand charger, BMS24 only make the relay OPEN, if charge current is big such as over 10A, the relay will open and close repeatedly. The relay life will be shortened and charge time will be longer.

Chargery charger and BMS save a relay cost and shorten the charge time.



### NOTE

Chargery charger decrease charge current according to "Over Charge Protection(P) Voltage" on BMS setup, so please setup the charge terminal voltage setup in accordance with Over Charge Protection(P) Voltage on BMS.





## Version History

Software Version	Description
V1.05	Released first time
V1.06	Fix press STOP enter into sleep mode, and Beeper & LED warning.
V1.07	Support LTO battery, model is BMS24T
V1.11	Negative temperature can be measured.
V1.12	Add charge protection, Don't charge under 2°C
V1.13 (Hardware V2.2)	Add display module, improve voltage bar graph display, the lowest negative 20°C can be detected
V1.14	Fix the charge and discharge WH bug
V1.15	SOC can be setup to 0%
V1.16	Start automatically on battery type and cell count setup interface, need not press START button.
V1.21	<ul style="list-style-type: none"> <li>● Fix a bug when display temperature difference at F.</li> <li>● Fix a bug on adjusting balance start voltage on LiTo battery</li> <li>● Add balance control item in storage status on Program Setup interface <ul style="list-style-type: none"> <li>---balance in Storage on or off</li> <li>-- balance in Charge on or off</li> <li>-- balance in Discharge on or off</li> </ul> </li> </ul> <p><b>Charge status:</b> charge current displayed over 1A</p> <p><b>Discharge status:</b> discharge current display under -1A, such as -10A</p> <p><b>Storage status:</b> current displayed between -1A ~ 1A</p> <p>So current shunt and current sensor wire must be connected to BMS main unit.</p> <ul style="list-style-type: none"> <li>● Improved SoC of LiTo battery</li> </ul>



## Warranty and Service

Chargery Power Co., Ltd. as manufacture of power system warrants its BMS24T and current Sensor to be free of defects in material and workmanship. This warranty is effective for 12 months from date of purchase. If within the warranty period the customer is not satisfied with the products performance resulting from a manufacturing defect, the accessory will be replaced or repaired.

Your selling dealer is your first point of contact for warranty issues. Return postage costs are the responsibility of the user in all cases. Please submit copy of original receipt with the return.

Damage due to physical shock (dropping on the floor, etc.), inappropriate power supply (unstable output voltage and insufficient power, etc.), water, moisture, and humidity are specifically NOT covered by warranty.



### Chargery Power Co., LTD.

Chuangye Road, Nanshan Shenzhen, 518054, China.

Tel: 86 (0)755 26436165, fax: 86 (0) 755 26412865

Email: [jasonwang3a@163.com](mailto:jasonwang3a@163.com)

Homepage: [www.chargery.com](http://www.chargery.com)

